

LOC	DIST	REVISIONS			
P	LTR	DESCRIPTION	DATE	DWN	APVD
-	-	NC	NEW RELEASE PER E.O. A14915	04DEC1995	- RDR
		A	REVISED PER E.O. P18134	23MAY2003	- RDR
		B	REVISED PER E.O. P18565	20SEP2004	- RDR
		B1	REVISED PER ECO-15-001798	12AUG2014	PV DM

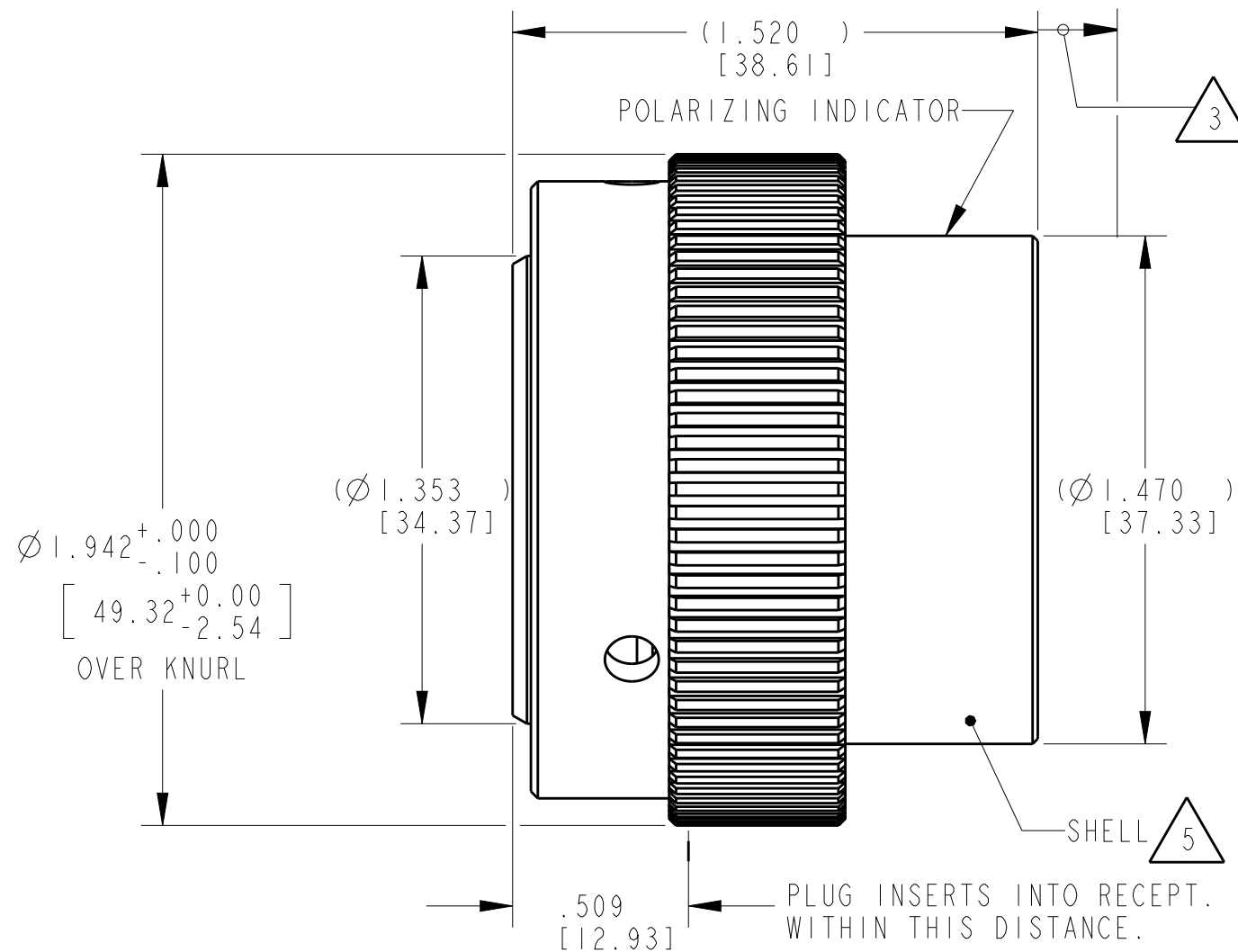
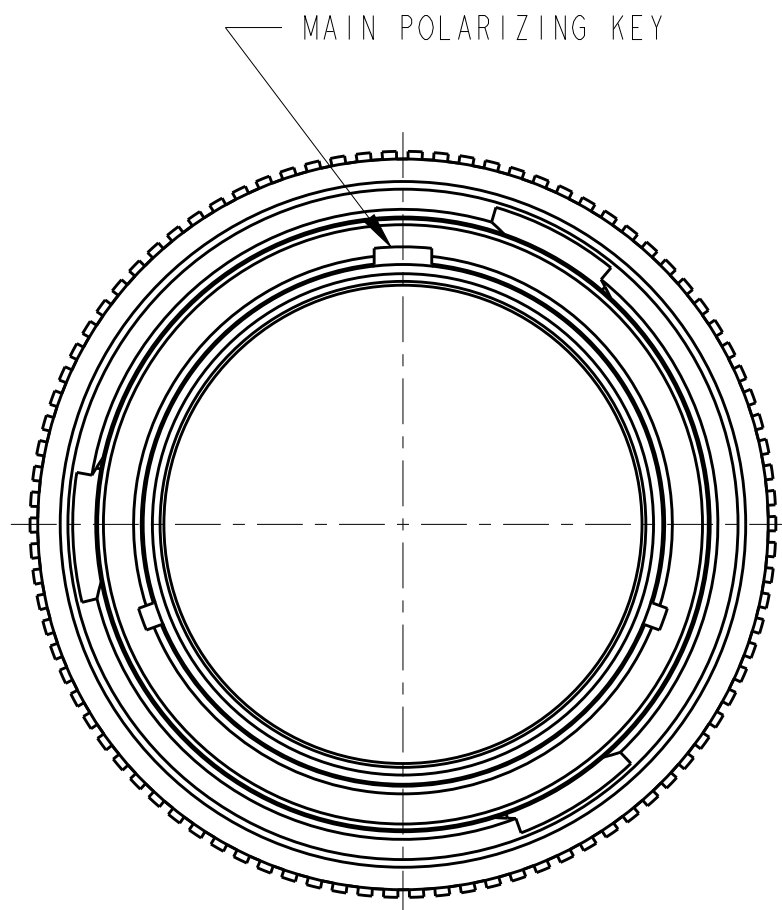

5. MATERIAL:
 PLUG HOUSING: AL 6000 SERIES
 SHELL MATERIAL: METAL
 INSULATOR : PLASTIC

4. THIS SHELL MATES WITH HD34-24-XXP/SX-XXXX

3. TOTAL DIM. WITH EXTENDED WIRE SEAL (WITH CONTACTS #4 OR #8 ONLY) = 1.750±.050 [44.45±1.27].

2. SEE DRAWING 0425-014-2400 FOR ARRANGEMENT OF CONTACT LOCATION.

1. CONSULT THE FACTORY FOR ELECTRICAL AND MATERIAL SPECIFICATIONS.

NOTES:

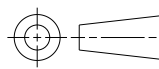
THIS DRAWING IS A CONTROLLED DOCUMENT.		DWN 30OCT2014 VIJETH BHARADWAJ	 TE Connectivity	
DIMENSIONS: INCHES [mm]		CHK 31OCT2014 I. GRANTCHAROVA		
TOLERANCES UNLESS OTHERWISE SPECIFIED:		APVD 31OCT2014 D. MEYER	PLUG CONNECTOR, SHELL SIZE 24 BAYONET COUPLING HD30 SERIES	
		PRODUCT SPEC 0425-015-0000	SIZE	RESTRICTED TO
MATERIAL SEE NOTE		APPLICATION SPEC 0425-016-0000	A3	-
FINISH -		WEIGHT -	CAGE CODE	DRAWING NO
		Customer Drawing	-	© HD36-24-XXP/SX
			SCALE 2:1	SHEET 1 OF 1 REV B1